



Tank Multi Blender



STORAGE FACILITY & CONTINUOUS FLOW BLENDING SYSTEM

The Tank Multi-Blender combines the simplicity and affordability of vertical storage with the speed and accuracy of Ranco's volumetric metering system to provide the only test

proven tank blend facility available today. Be a part of the expanding number of retailers utilizing this true one-person operation to grow with the ever-changing dry fertilizer industry.

TIME PROVEN



Manufacturing Quality Fertilizer Handling Equipment For Over 30 Years.



RECEIVING BUCKET ELEVATOR - 100 TPH capacity, fiberglass and stainless steel.

OVERHEAD AUGER - 60 to 110 TPH, fiberglass and stainless steel.

REMOTE CONTROLS for blending system and system checks. There are ammeters at the control panel to monitor the meter screws; the equipment is totally interlocked.

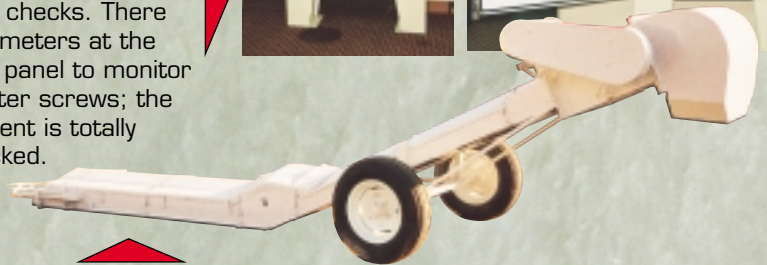
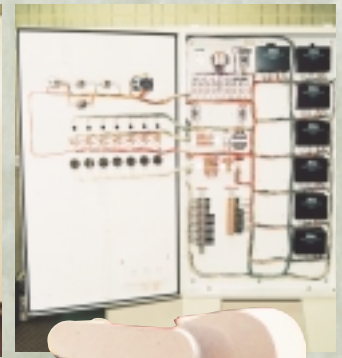

PORTABLE OR PERMANENT UNLOADERS - 60 TPH to 110 TPH, stainless steel.

METERING UNIT AND BLEND AUGER

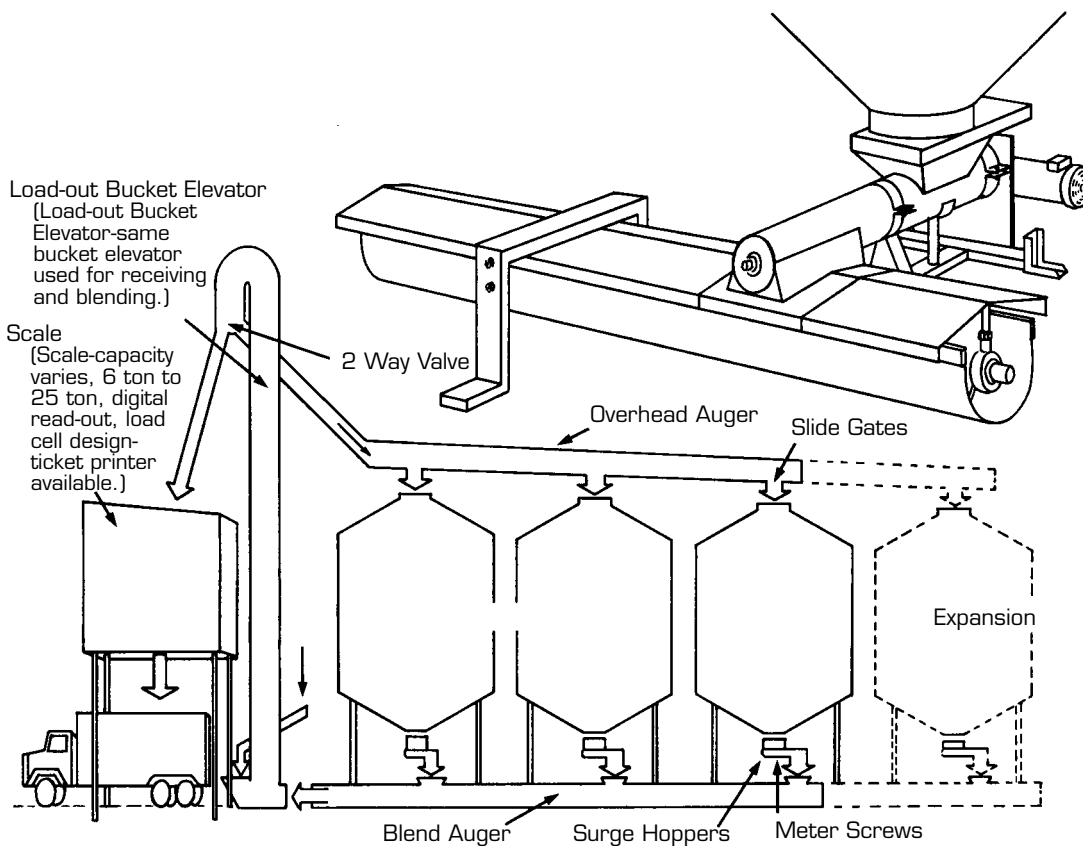

- The metering unit is an auger which meters product out of the tank and into the u-trough auger where the product is blended. The metering auger has a variable speed drive to set each of your individual blends.
- Trace elements and chemicals are easily added to any blend by the use of a portable micro nutrient bin or an impregnation unit.
- Environmentally safe. The various pieces of equipment are totally enclosed, and there is no exposure of the product to the elements.



P.O. Box 329
Sioux Rapids, Iowa 50585
Phone: 712-283-2525